

# Little GIANT<sup>®</sup>

## Pump Company

### NK-1 SERIES



#### Features

- Corrosion resistant nylon body
- Oil-filled motor
- 10.2' maximum lift
- 70 watts
- 1/4" MNPT discharge
- Thermal overload protection
- For submersible use only

#### Construction

- Motor — 1/150 HP Oil Filled
- Intermittent Liquid Temp. up to — 120° F
- Intake — N/A
- Discharge — 1/4" MNPT
- Housing — Nylon
- Cover — Nylon
- Volute — Nylon
- Impeller — Nylon
- Shaft Seal — Viton<sup>®</sup>
- Screen — Polyethylene

Small submersible oil-filled pump with corrosion resistant nylon housing. For commercial, industrial and home applications including statuary fountains, water displays, air conditioners, machine tool coolants, and many other applications where liquid must be transferred or recirculated. This compact 210 GPH pump features a 1/4" MNPT discharge, 10.2' shut-off head capability, and screened inlet.

# Little Giant Pump Co.

## NK-1 SERIES

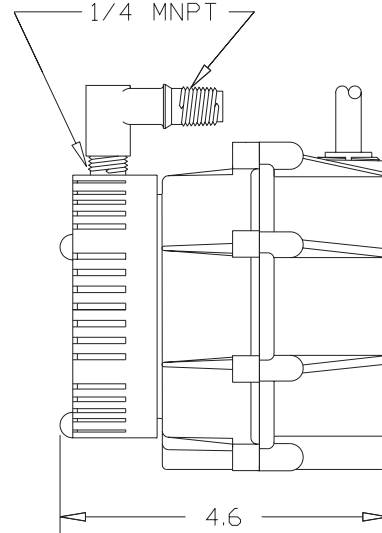
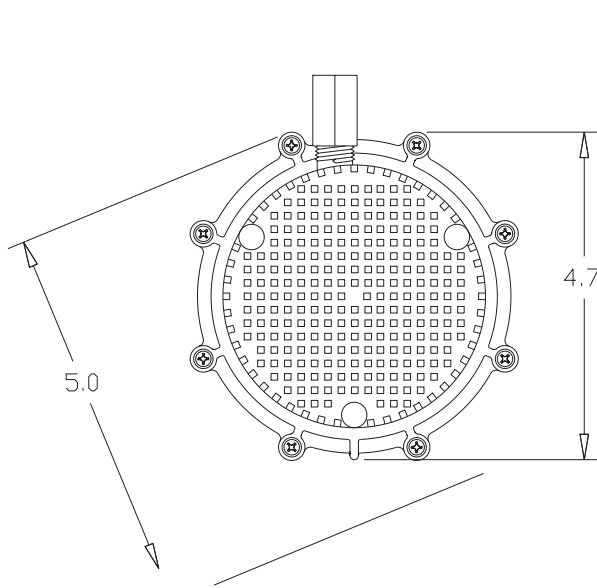

### Specifications

Model No.	Item No.	Discharge Size	HP	Volts	Hertz	Amps	Watts	Performance (GPH @ Head)			Shut Off Feet	PSI	Pwr. (ft)	Cord Weight (Lbs.)
								1'	3'	5'				
NK-1	526003	1/4" MNPT	1/150	115	60	1.1	70	210	180	150	10.2	4.4	6	3.67

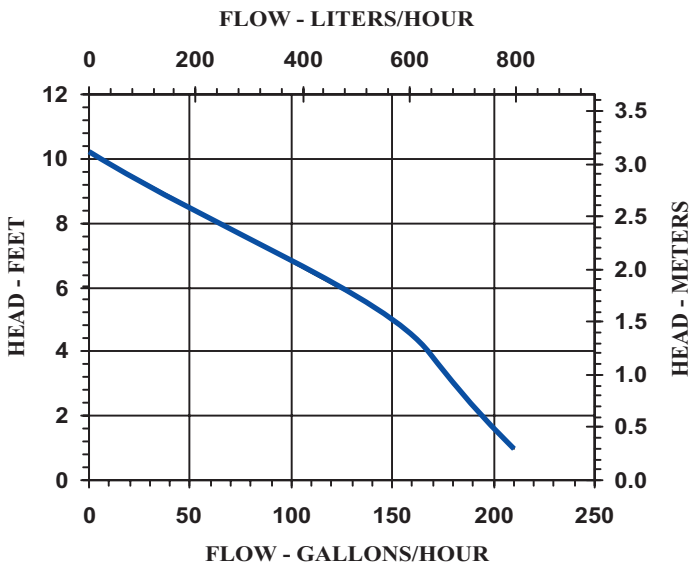

### Replacement Parts

Volute	116375
Impeller	116437
Screen	101376
Seal Ring	928007
Back Plate	126377
Elbow	943076

### Little Giant Pump Co.

PO Box 12010  
Okla. City, OK 73157

Phone: 405.947.2511  
Fax: 405.228.1550

[www.LittleGiantPump.com](http://www.LittleGiantPump.com)